

NDA-WMT-MICDOME Microdome Pendant Wall Mount

www.boschsecurity.com



BOSCH
Invented for life



- ▶ Sturdy construction
- ▶ Easy installation
- ▶ Hollow core for cable-free appearance
- ▶ Tough 4-bolt anchoring

This easy-to-install and sturdy wall mount is specifically designed for indoor/outdoor dome cameras. The design enables complete cable management, concealing wires for maximum protection and aesthetics.

Installation/configuration notes

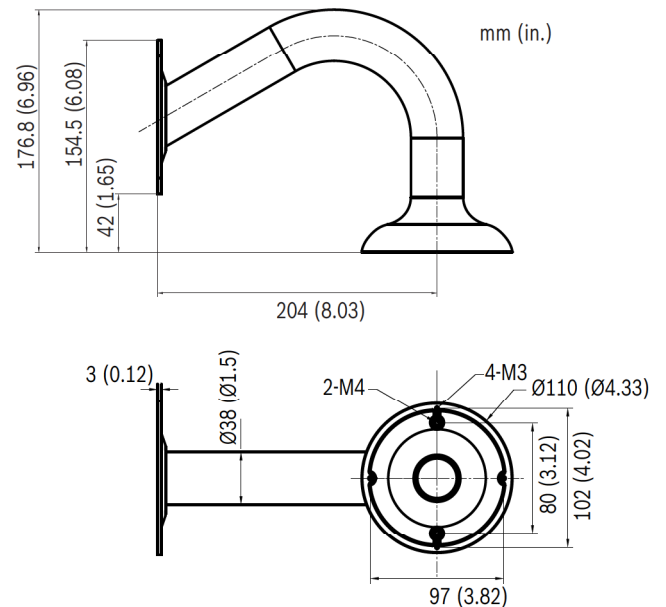
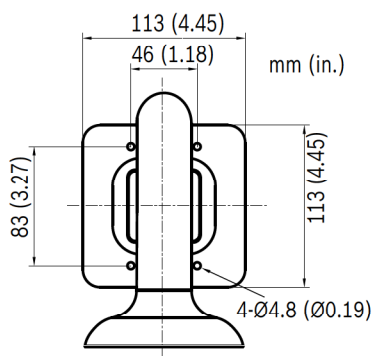

Technical specifications

Construction material	Aluminum alloy
Finish	RAL 9003 signal white
Weight	0.6 kg (1.32 lb)

Ordering information

NDA-WMT-MICDOME Microdome Pendant Wall Mount

Sturdy wall mount bracket for microdome cameras
(Ø110 mm)

Order number **NDA-WMT-MICDOME**

Represented by:

Americas:

Bosch Security Systems, Inc.
130 Perinton Parkway
Fairport, New York, 14450, USA
Phone: +1 800 289 0096
Fax: +1 585 223 9180
security.sales@us.bosch.com
www.boschsecurity.us

Europe, Middle East, Africa:

Bosch Security Systems B.V.
P.O. Box 80002
5617 BA Eindhoven, The Netherlands
Phone: + 31 40 2577 284
Fax: +31 40 2577 330
emea.securitysystems@bosch.com
www.boschsecurity.com

Asia-Pacific:

Robert Bosch (SEA) Pte Ltd, Security
Systems
11 Bishan Street 21
Singapore 573943
Phone: +65 6571 2808
Fax: +65 6571 2699
apr.securitysystems@bosch.com
www.boschsecurity.asia

China:

Bosch (Shanghai) Security Systems Ltd.
203 Building, No. 333 Fuquan Road
North IBP
Changning District, Shanghai
200335 China
Phone +86 21 22181111
Fax: +86 21 22182398
www.boschsecurity.com.cn

America Latina:

Robert Bosch Ltda Security Systems Division
Via Anhanguera, Km 98
CEP 13065-900
Campinas, Sao Paulo, Brazil
Phone: +55 19 2103 2860
Fax: +55 19 2103 2862
latam.boschsecurity@bosch.com
www.boschsecurity.com